

SCALE 0.220

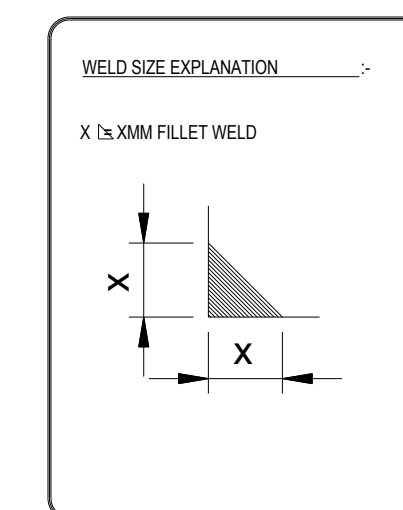

DESCRIPTION				
CP60 PULVERISER DIRECT MOUNT				
ST REFERENCE No				ISSUED
ST PART No				DRG SIZE AO
DRAWN	DATE	CHECKED	DATE	SCALE
HSB	DEC14			SEE DRG
TOTAL NUMBER OF SHEETS 1			THIS SHEET NO 1	

© STRICKLAND DIRECT LIMITED 2003 ALL DESIGN RIGHTS OR OTHER INTELLECTUAL PROPERTY RIGHTS IN THIS DESIGN AND THE COPYRIGHT IN THIS DRAWING ARE THE PROPERTY OF STRICKLAND DIRECT LIMITED. ANY UNAUTHORISED USE THEREOF WILL CONSTITUTE AN INFRINGEMENT OF THE INTELLECTUAL PROPERTY RIGHTS OF STRICKLAND DIRECT LIMITED.

STRICKLAND DIRECT
PART OF THE STRICKLAND GROUP

TOLERANCES ON WELDED ASSEMBLIES (UNLESS OTHERWISE STATED)
0 - 1000mm ± 2.0
1000 - 2000mm ± 3.0
Over 2000mm ± 5.0

MACHINED TOLERANCES (UNLESS OTHERWISE STATED)
1 DEC PLACE ± 0.25
2 DEC PLACE ± 0.12

ANY UNNECESSARY SHARP EDGES TO BE REMOVED.

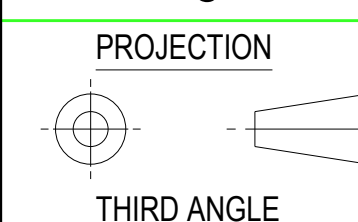

IF IN DOUBT-PLEASE ASK DO NOT SCALE

DXF FILE